

CIRCULAR SCALE METER FOR SWITCHBOARD INSTRUMENTS



L-110C



PK-60C



PK-100C



PK-120C



PK-80C

■ USAGE

DKWL series are circular scale instruments manufactured using DC Taut-band suspension method and the built-in transducer system.

All meters exceed the requirements of Japanese Standards JIS C-1102 and C-1103, and ANSI 39.1 (option)

■ L SERIES (110*110mm)

■ PK SERIES (80*80,100*100mm)

ITEM		PRINCIPLE	TYPE	CLASS	ITEM		PRINCIPLE	TYPE	CLASS
DC Voltmeter		Moving coil	ML-110C	1.5	DC Voltmeter		Moving coil	PMK-80	2.5
DC Ammeter			ML-110C	1.5	DC Ammeter			PMK-80	2.5
AC Voltmeter		Transducer	CL-110NC	1.5	AC Voltmeter		Transducer	PSK-80	2.5
AC Ammeter			CL-110NC	1.5	AC Ammeter			PSK-80	2.5
Watt meter	1φ2W	Transducer	WL-110NC-12	1.5	Watt meter	1φ2W	Transducer	PWK-100NC-12	2.5
	1φ3W		WL-110NC-13	1.5		1φ3W		PWK-100NC-13	2.5
	3φ3W		WL-110NC-33	1.5		3φ3W		PWK-100NC-33	2.5
	3φ4W		WL-110NC-34	1.5		3φ4W		PWK-100NC-34	2.5
Var meter	1φ2W	Transducer	WVL-110NC-12	1.5	Var meter	1φ2W	Transducer	PWVK-100NC-12	2.5
	1φ3W		WVL-110NC-13	1.5		1φ3W		PWVK-100NC-13	2.5
	3φ3W		WVL-110NC-33	1.5		3φ3W		PWVK-100NC-33	2.5
	3φ4W		WVL-110NC-34	1.5		3φ4W		PWVK-100NC-34	2.5
power factor meter	1φ2W	Transducer	PL-110NC-12	5.0	power factor meter	1φ2W	Transducer	PPK-100NC-12	5.0
	3φ3W(brace)		PBL-110NC-33	5.0		3φ3W(brace)		PPBK-100NC-33	5.0
	3φ3W(unbrace)		PL-110NC-33	5.0		3φ3W(unbrace)		PPK-100NC-33	5.0
	3φ4W(unbrace)		PL-110NC-34	5.0		3φ4W(unbrace)		PPK-100NC-34	5.0
Frequency meter		Transducer	AL-110NC	0.5	Frequency meter		Transducer	PAK-100NC	1.0

STANDARD SPECIFICATIONS

ITEM	SPECIFICATIONS		ITEM	SPECIFICATIONS	
	L SERIES	PK SERIES		L SERIES	PK SERIES
Standard	JIS C-1102,C-1103		Cover color	Black (Mansell N1.5)	
Accuracy class	See first page " L & PK series"		Case material	Cover (Methacrylic acid resin)	
Angle of deflection	250°	86°		Bass (ABS resin)	
Scale length	200mm	45~95mm	Withstand voltage		
Scale color	White		between circuit and outercase voltage	AC 2600, 1min	AC 2000V, 1min
Pointer	Lance type (black)				
Mounting position	Vertical (⊥)		voltage	AC 500V	
Operational Temperature	-10 ~ 55°C		Operational Humidity	40 ~ 85%RH	

L SERIES DIMENSIONS (unit=mm)

	PANEL CUT-OUT	TYPE
		ML-110NC CL-110NC AL-110NC
		WL-110NC WVL-110NC PL-110NC PBL-110NC

PK SERIES DIMENSIONS (unit=mm)

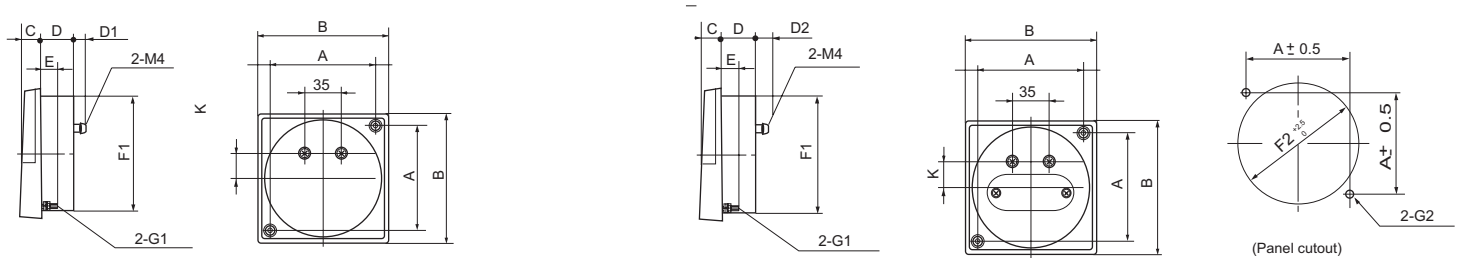

Type	A	B	C	D	D1	D2	E	F1	F2	G1	G2	K	Weight(g)
PSK-120C	100	123	20	31.5	10	16.5	15	110 ϕ	112 ϕ	M5	7 ϕ	24	370
PSK-100C	80	100	16	31.5	10	16.5	15	85 ϕ	87 ϕ	M4	5.5 ϕ	15	260
PSK-80C	64	80	14.5	29.5	8	16	10	65 ϕ	67 ϕ	M3	4 ϕ	0	165
PSK-60C	48	60	14.5	29.5	8	16	10	52 ϕ	54 ϕ	M3	4 ϕ	6	130

CONNECTION DIAGRAM (L SERIES)

ML

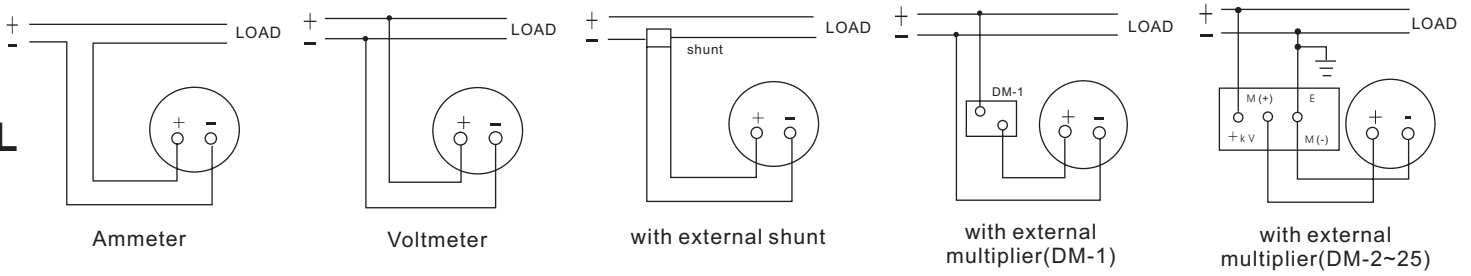

CL

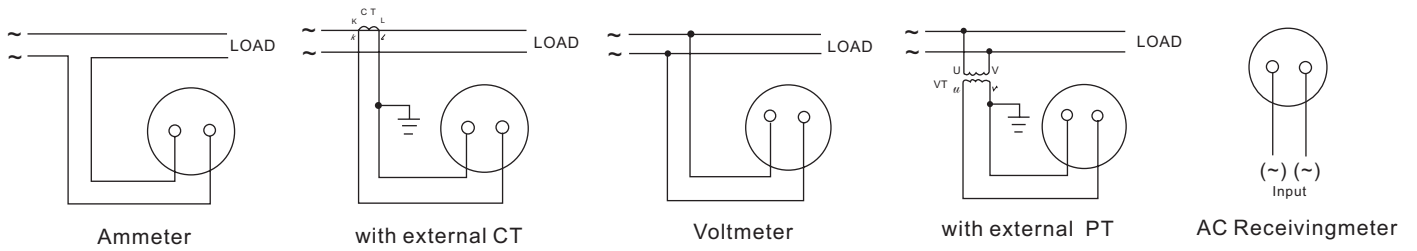

WL

WVL

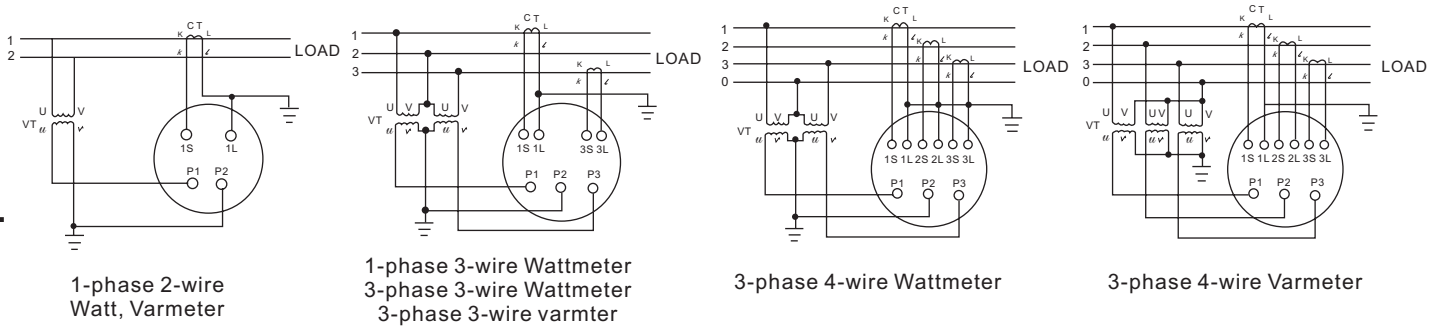

PL

PBL

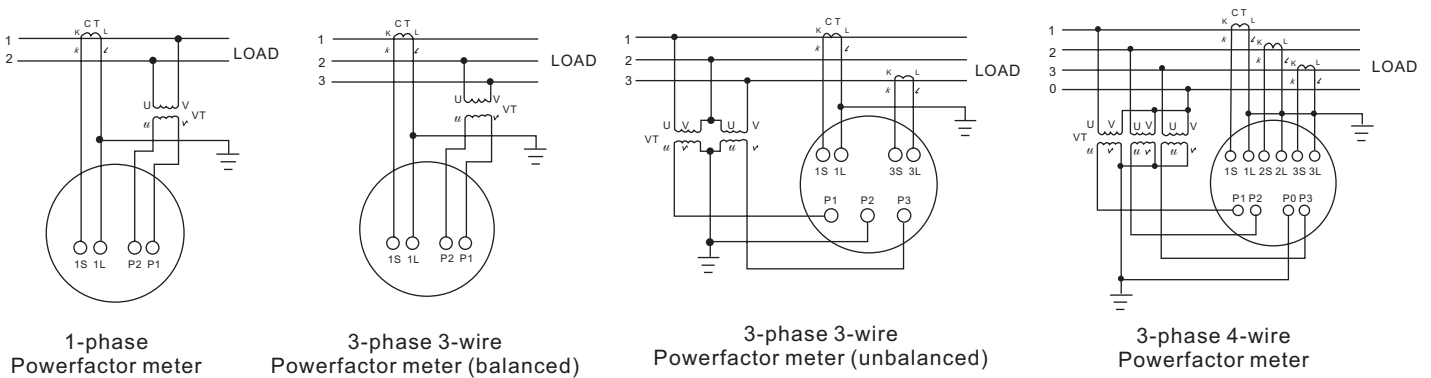

AL

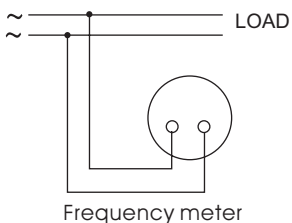

CONNECTION DIAGRAM (PK SERIES)

